



MODEL TECV-XXXS

STATIONARY COOKING VESSEL

GENERAL DESCRIPTION

The TUCS STATIONARY COOKING VESSEL is a low rim height, trough-shaped vessel with a horizontal mixing scraper agitator for the production of liquid, semi-viscous and viscous products (soups, sauces, stews, mashed potatoes, refried beans, etc.). This agitator lifts the heavy particulate off the bottom and moves it to the top while pulling the floating particulate to the bottom, in a gentle mixing, folding action. The vessel has a 3" air-operated, flush-mounted drop-down valve for the attachment to a Tucs volumetric piston pump or other pumping devices. Pre-piped for single point attachment to utilities and a complete integrated digital control panel with a pendant mounted digital HMI.



Two 100-Gallon Stationary Cooking Vessels

CERTIFICATIONS

ANSI/UL-197, NSF/ANSI-4



TUCS Equipment, Inc.
755 County Road 18 S. • Princeton MN 55371
Phone 763-574-7475 Fax 763-574-7472
www.tucsequipment.com

ITEM NO.

PROJECT

QUANTITY

AIA NO.

CAPACITIES

50, 100, 150, 200, 300, and 400-gallon working capacity

CONSTRUCTION & FEATURES

All stainless-steel construction type 316L product contact surfaces, type 304L elsewhere ■ Mounted on a stainless-steel frame with 4 adjustable legs and anchor pads ■ Steam jacket is laser welded, dimple construction and channeled to assure uniform distribution of steam and chilled water ■ ASME code rated for 150 PSI max steam pressure ■ Insulated steam jacket for operator safety ■ Pre-piped for single point connections to utilities ■ Slide out operator convenience step (150 gallons and larger) ■ Pneumatic operated safety grate and lid ■ Water meter and fill hose ■ Kettle side is engraved for water or product level in 50 gallon increments ■ Flexible connectors for all specified utilities (See Note #4)

AGITATOR SYSTEM

Swept surface horizontal agitator design ■ Agitator easily removable without tools ■ Single horizontal shaft with scraper blades and alternate paddles ■ Blades offset 90 degrees, Delrin scraper blades are easily removable ■ TEFC drive motor with right angle gear box ■ Variable frequency motor speed drive ■ Continuously variable from 0 to 18 rpm ■ Reversible direction

CONTROLS

NEMA 4X control enclosure attached to kettle below rim ■ Controls mounted right or left side of cooking vessel per kitchen plan ■ Allen Bradley PLC with pendant mounted touch screen HMI, controls all functions ■ Recipe storage ■ Temperature control ■ Electronic temperature recording ■ EWON (Router), Internet connection to TUCS for remote diagnostics

OPTIONS

- Split jackets with up to 2 heating zones
- Low pressure steam loop for low pressure cooking (-LPSL)
- Jacket cooling
- Agitator removal cart (TEARC-xxx)
- Agitator storage cart (TEASC-xxx)
- Drain valve extension with manual ball valve for rendering off fat when cooking proteins
- Slide out convenience step (100-gallon)

MODEL TECV-XXXS

STATIONARY COOKING VESSEL

Scan this QR code with your smart phone to visit our website for more information.

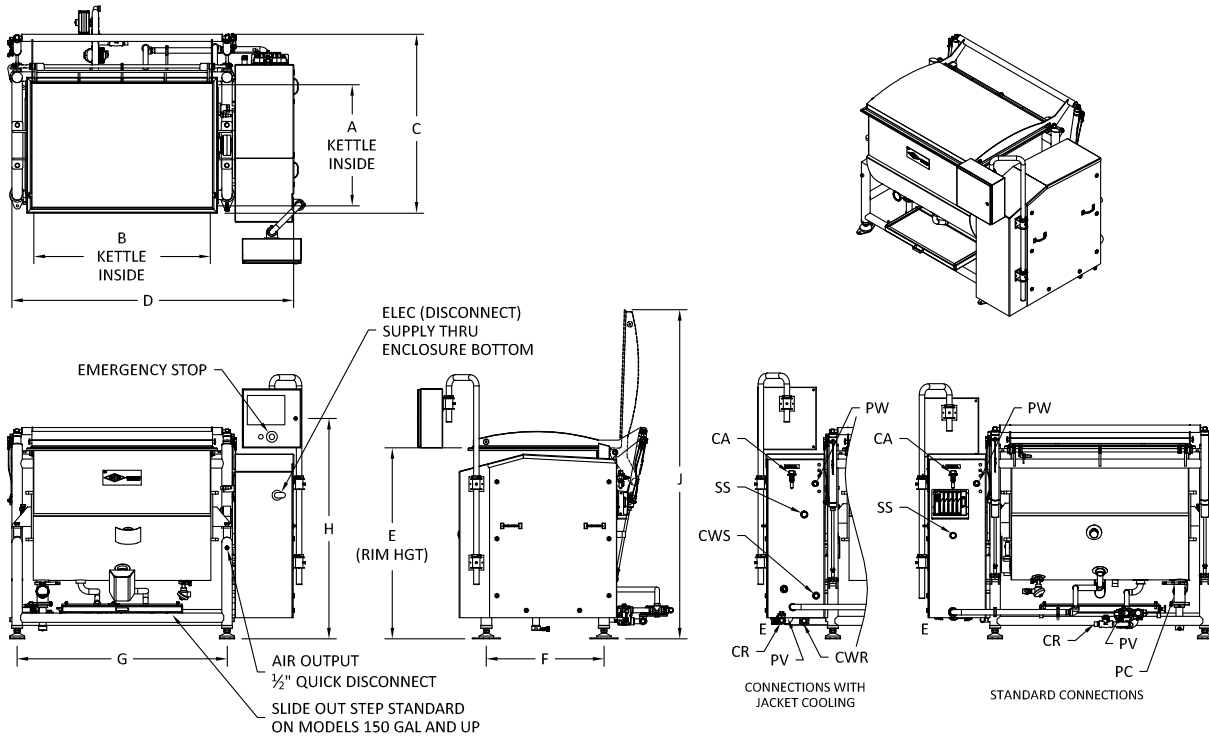

NOTES:

1. SHOWN WITH CONTROL ON RIGHT SIDE. LEFT SIDE AVAILABLE.
2. POTABLE WATER GPM DEPENDANT ON SIZE OF MAIN WATER LINE AND WATER LINE PRESSURE.
3. COMPRESSED AIR RATING SHOWN FOR KETTLE USE ONLY. INCREASED CFM REQUIRED FOR ADDITIONAL EQUIPMENT.
4. FLEXIBLE CONNECTOR HOSES (36\"L) PROVIDED BY TUCS FOR CA, SS, CR, PW, CWS, AND CWR. INSTALLER MUST PROVIDE STAINLESS ELBOWS OR STREET ELBOWS WHEN MAKING FINAL CONNECTIONS.
5. CUSTOMER TO PROVIDE REGULATED WATER PRESSURE NOT TO EXCEED 60 PSI.

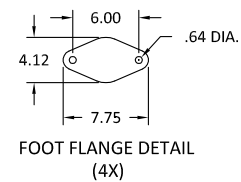

UTILITY CONNECTIONS

SIZE	COMPR. AIR	STEAM SUPPLY	COND. RETURN	PURGE VALVE	POTABLE WATER	PUMP CONNECT	(OPTION)	(OPTION)
							CHILLED NONPOTABLE SUPPLY	CHILLED NONPOTABLE RETURN
SYMBOL	CA	SS	CR	PV	PW	PC	CWS	CWR
50	1/2" QD	1" NPT	3/4" NPT	1/2" NPT	1" NPT	3" DC	1" NPT	1" NPT
100	1/2" QD	1" NPT	1" NPT	1/2" NPT	1" NPT	3" DC	1" NPT	1" NPT
150	1/2" QD	1 1/4" NPT	1" NPT	1/2" NPT	1" NPT	3" DC	1" NPT	1" NPT
200	1/2" QD	1 1/4" NPT	1" NPT	1/2" NPT	1" NPT	3" DC	1" NPT	1" NPT
300	1/2" QD	1 1/2" NPT	1" NPT	1/2" NPT	1" NPT	3" DC	1 1/4" NPT	1 1/4" NPT
400	1/2" QD	1 1/2" NPT	1 1/4" NPT	1/2" NPT	1" NPT	3" DC	1 1/4" NPT	1 1/4" NPT

DIMENSIONS

SIZE	A	B	C	D	E	F	G	H	J
50	24	28	41	58	45	26	37	60	75
100	28	34	44	63	47	28	43	60	80
150	30	44	46	73	49	31	53	60	84
200	33	48	49	77	53	32	57	60	91
300	38	54	55	83	59	36	64	60	101
400	42	60	59	90	62	40	70	60	108

UTILITY REQUIREMENTS

SIZE	COMPR. AIR	STEAM JKT 150 PSI MAX	POTABLE WATER 60 PSI MAX	ELECTRIC (ELEC) 3 PH/60 Hz			SHIPPED WEIGHT	
				AGITATOR MOTOR	FLA @ 208V	FLA @ 240V		FLA @ 480V
GAL	CFM @ 90 PSI	LB/HR MAX @ 100 PSI	MAX GPM				LBS	
50	1	380	20	1/2 HP	4.2 A	3.7 A	1.9 A	950
100	1	611	20	1 HP	6.0 A	5.3 A	2.7 A	1150
150	1	869	20	1 1/2 HP	7.6 A	6.7 A	3.4 A	1450
200	1	1,060	20	1 1/2 HP	7.6 A	6.7 A	3.4 A	1800
300	1	1,386	20	2 HP	9.8 A	8.6 A	4.3 A	1950
400	1	1,589	20	2 HP	9.8 A	8.6 A	4.3 A	2150

FACTORY SUPPLIED STEAM PRESSURE RELIEF VALVE @125 PSI.

RECOMMENDED CLEARANCES (RIGHT HAND KETTLE)

RIGHT SIDE	24"
FROM BACK LEG	22"
LEFT SIDE	12"

12/10/2021

Due to continuous improvements, specifications subject to change without notice.

© 2021 TUCS Equipment. All Rights Reserved. Printed in the USA.